



## TEAM CONTEST

2<sup>nd</sup> July 2013 Burgas, Bulgaria

Team : \_\_\_\_\_ Score : \_\_\_\_\_

- Each of the numbers 0, 1, 2, 3, 4, 5, 6, 7, 8 and 9 is to be put into a different circle in the diagram below. Consecutive numbers may not be put into two circles connected directly by a line segment. The sum of the numbers in the circles on the perimeter of each rectangle is equal to the number indicated inside. On the diagram provided for you to record your answer, put the numbers into the circles.

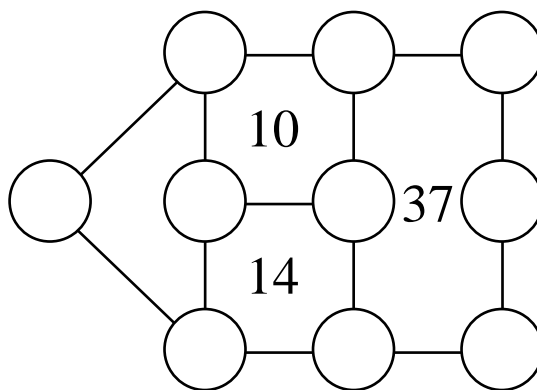
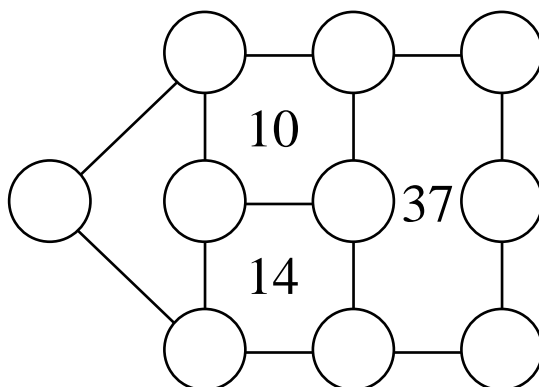

Answer: \_\_\_\_\_

## TEAM CONTEST

2<sup>nd</sup> July 2013 Burgas, Bulgaria

Team : \_\_\_\_\_ Score : \_\_\_\_\_

2. The side lengths, in cm, of a right triangle are relatively prime integers. The line joining its centroid and its incentre is perpendicular to one of the sides. What is the maximum perimeter, in cm, of such a triangle?

Answer: \_\_\_\_\_ cm

## TEAM CONTEST

2<sup>nd</sup> July 2013 Burgas, Bulgaria

Team : \_\_\_\_\_ Score : \_\_\_\_\_

3. A marker is placed at random on one of the nine circles in the diagram below. Then it is moved at random to another circle by following a line segment. What is the probability that after this move, the marker is on a circle marked with a black dot?

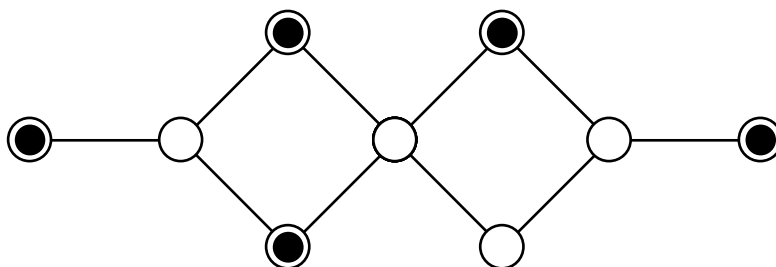

Answer: \_\_\_\_\_

## TEAM CONTEST

2<sup>nd</sup> July 2013 Burgas, Bulgaria

Team : \_\_\_\_\_ Score : \_\_\_\_\_

4. In triangle  $ABC$ ,  $\angle A = 40^\circ$  and  $\angle B = 60^\circ$ . The bisector of  $\angle A$  cuts  $BC$  at  $D$ , and  $F$  is the point on the line  $AB$  such that  $\angle ADF = 30^\circ$ . What is the measure, in degrees, of  $\angle DFC$ ?

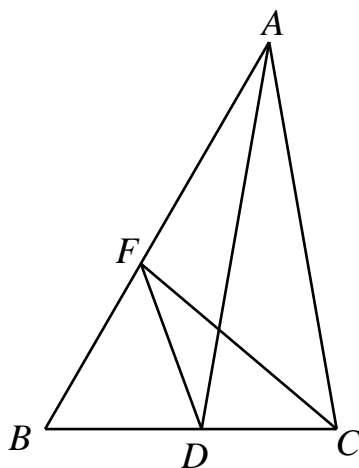

o

Answer: \_\_\_\_\_

## TEAM CONTEST

2<sup>nd</sup> July 2013 Burgas, Bulgaria

Team : \_\_\_\_\_ Score : \_\_\_\_\_

5. The first digit of a positive integer with 2013 digits is 5. Any two adjacent digits form a multiple of either 13 or 27. What is the sum of the different possible values of the last digit of this number?

Answer: \_\_\_\_\_

## **TEAM CONTEST**

2<sup>nd</sup> July 2013 Burgas, Bulgaria

Team : \_\_\_\_\_ Score : \_\_\_\_\_

6. In a tournament, every two participants play one game against each other. No game may end in a tie. The tournament record shows that for any two players X and Y, there is a player Z who beats both of them. In such a tournament,
- (a) prove that the number of participants cannot be six;
  - (b) show that the number of participants may be seven.

## TEAM CONTEST

2<sup>nd</sup> July 2013 Burgas, Bulgaria

Team : \_\_\_\_\_ Score : \_\_\_\_\_

7. In the pentagon  $ABCDE$ ,  $\angle ABC = 90^\circ = \angle DEA$ ,  $AB = BC$ ,  $DE = EA$  and  $BE = 100$  cm. What is the area, in  $\text{cm}^2$ , of  $ABCDE$ ?

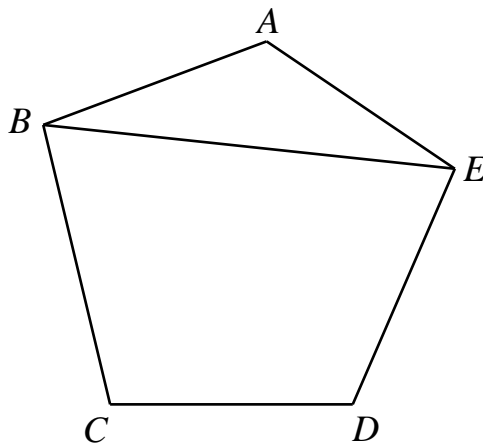

Answer: \_\_\_\_\_  $\text{cm}^2$



## TEAM CONTEST

2<sup>nd</sup> July 2013 Burgas, Bulgaria

Team : \_\_\_\_\_ Score : \_\_\_\_\_

8. A two-player game starts with a marker on each square of a  $100 \times 100$  board. In each move, the player whose turn it is must remove a positive number of markers. They must come from squares forming a rectangular region which may not include any vacant square. The player who removes the last marker loses. A sample game on a  $4 \times 4$  board is shown in the diagram below, where the first player loses. Which player has a winning strategy, the one who moves first or the one who moves second?

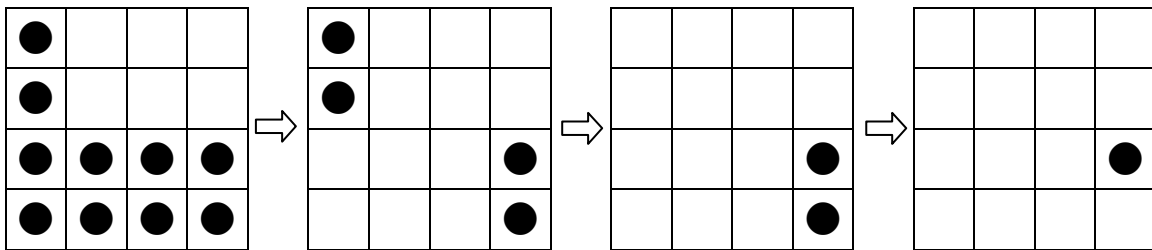

Answer: \_\_\_\_\_

## TEAM CONTEST

2<sup>nd</sup> July 2013 Burgas, Bulgaria

Team : \_\_\_\_\_ Score : \_\_\_\_\_

9. In a  $5 \times 5$  display case there are 20 gems: 5 red, 5 yellow, 5 blue and 5 green. In each row and in each column, there is an empty cell and the other four cells contain gems of different colours. Twelve people are admiring the gems. Looking along a row or a column, each person reports the colour of the gem in the first cell, or the colour of the gem in the second cell if the first cell happens to be empty. Their reports are recorded in the diagram below, where R, Y, B and G stand for red, yellow, blue and green respectively. On the diagram provided for you to record your answer, enter R, Y, B or G in each of 20 of the 25 blank cells to indicate the colour of the gem in that cell.

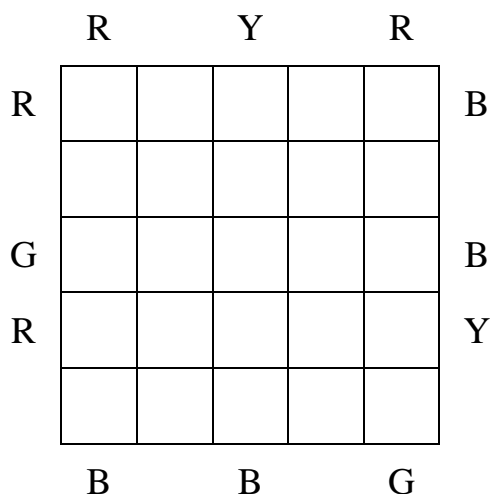
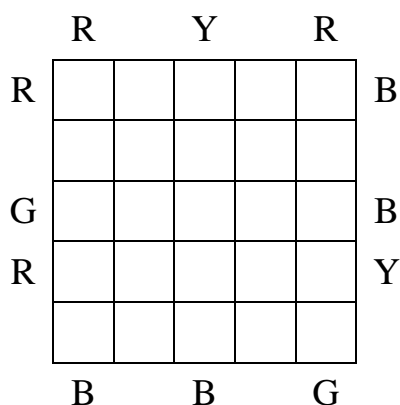

Answer: \_\_\_\_\_

## TEAM CONTEST

2<sup>nd</sup> July 2013 Burgas, Bulgaria

Team : \_\_\_\_\_ Score : \_\_\_\_\_

10. Four different stamps are in a  $2 \times 2$  block. The diagram below shows the 13 different connected subblocks which can be obtained from this block by removing 0 or more of the stamps. The shaded squares represent stamps that have been removed. How many different connected subblocks of stamps can be obtained from a  $2 \times 4$  block of eight different stamps?

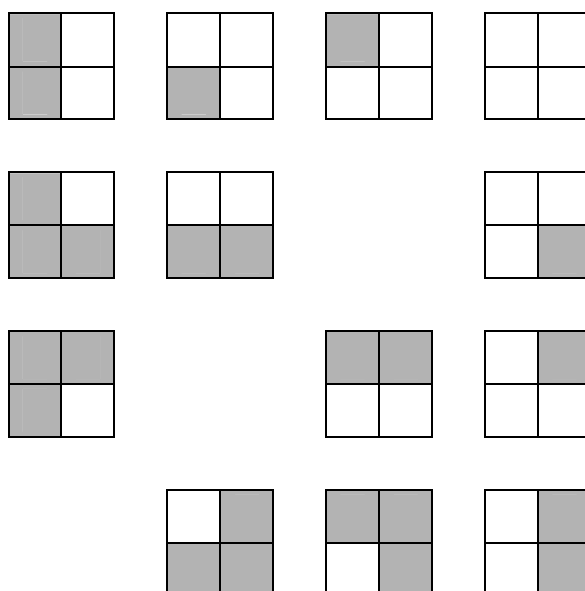

Answer: \_\_\_\_\_